

The list is showing all head-styles which are available in the series 09. The number shown right besides every picture is the part number used for ordering. Please replace the field "xx" by the spring force value you'd like to have. The available spring options are listed below.

Example of a completed ordering number:
09.02.07.12

Available spring forces with values in Newton (N) and ozs. and the adding code for the part number:

Code	Preload (N)	(oz.)	Rated Force (N)	(oz.)
<u>12</u>	1.0	3.46	1.2	4.15
<u>15</u>	0.4	1.38	1.5	5.19
<u>22</u>	0.8	2.77	2.2	7.61

Further Technical Data:

Minimum centre spacing:	1.9	mm	.075	inches
Extension height:	6	mm	.236	inches
Overall length:	30.65	mm	1.207	inches
Barrel diameter:	1	mm	.039	inches
Plunger shaft diameter:	0.75	mm	.03	inches
Maximum travel:	4	mm	.157	inches
Recommended (rated) travel:	2.7	mm	.106	inches
Temperature range:	-55°C ... +105°C		-67°F ... +221°F	
Typical electrical resistance:	20	mΩ		
Rated electrical current load:	3	amps		
Maximum current load:	4	amps		
Typical life-time in cycles:	1 x 10 ⁶	cycles		

Further spring forces and head styles available on request. Please allow longer delivery for special configurations.

For combination use with series 21 (100 MIL) and series 14 (50 MIL).

Materials:

Plunger:	CuBe or Tool Steel, gold plated
Barrel:	Nickelsilver, gold plated
Spring:	Music Wire, silver plated

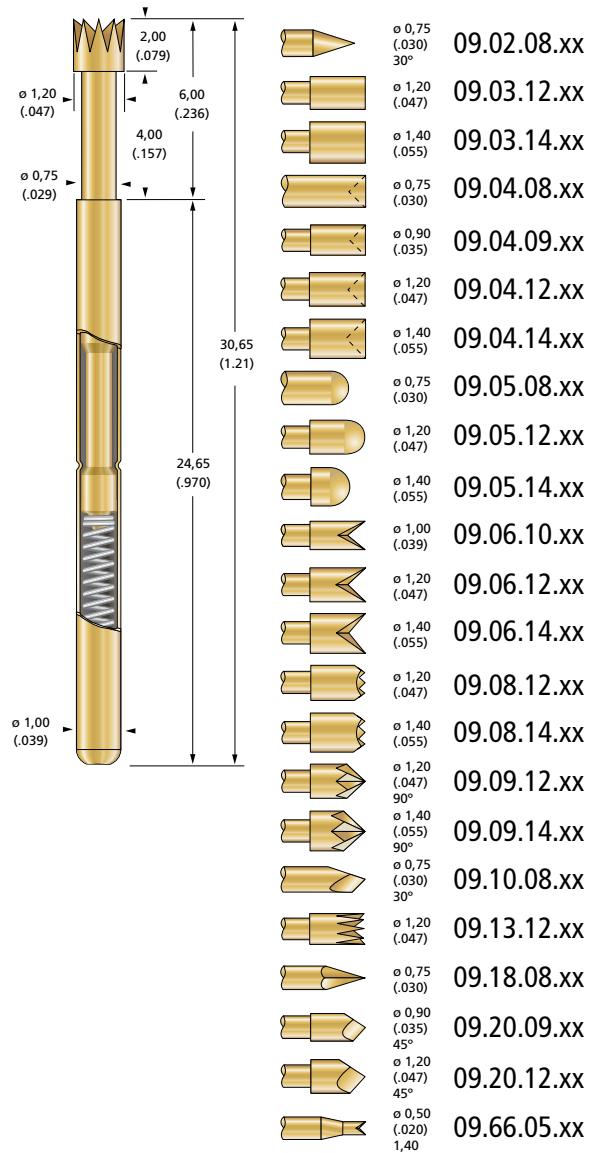

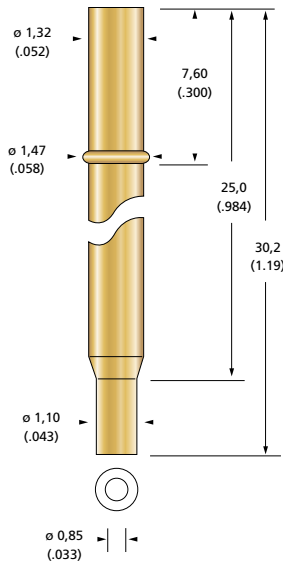

S 09.00-C
Open Crimp End

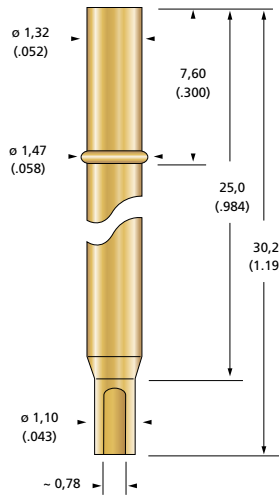

S 09.00-L
Solder Cup

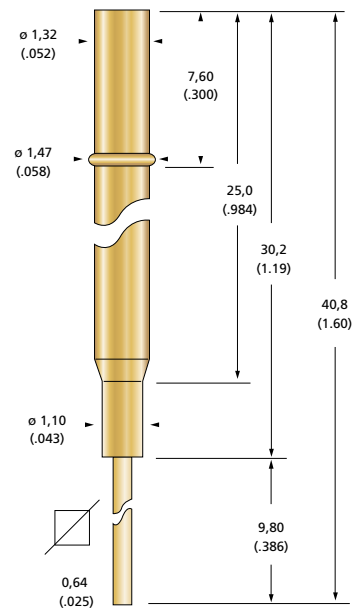

S 09.00-W
Wire-Wrap-Post

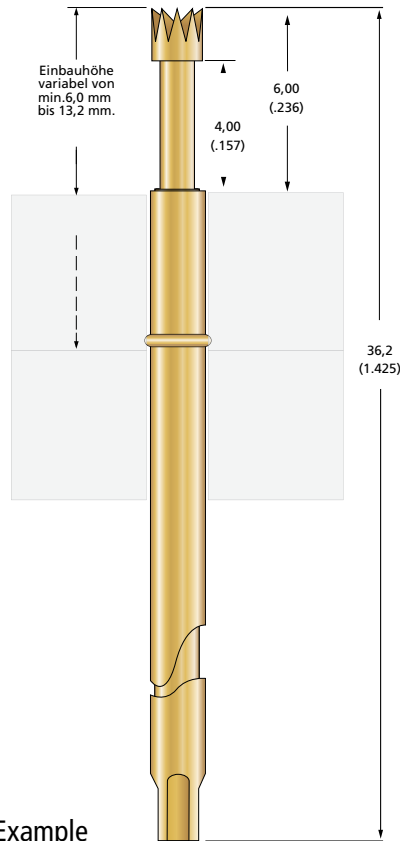

Fixturing Example

For the installation of the receptacles the mounting plate requires precise drilling. In the fixture business there are some typical base materials used for the pin plates which are different in drill bit diameters and machining parameters. The table is showing the recommended drill diameter and the order numbers needed when ordering drill bits from us. For machining parameters please consult factory.

Receptacle with Press-Ring, pressed into Plate Material			
Material	Drill- \varnothing		Part No.
CEM1 (also called EP105)	.0539 in.	1.37 mm	500-0137
FR4 (G10, Hgw 2372 or Hgw 2372.1)	.0551 in.	1.40 mm	500-0140
Press-Ring or Stop Ring used as a Collar			
CEM1 (also called EP105)	.0516 in.	1.31 mm	500-0131
FR4 (G10, Hgw 2372 or Hgw 2372.1)	.0520 in.	1.32 mm	500-0132