

The list is showing all head-styles which are available in the series 21. The number shown right besides every picture is the part number used for ordering. Please replace the field „xx” by the spring force value you’d like to have. The available spring options are listed below.

Example of a completed ordering number:
21.02.10.10

Available spring forces with values in Newton (N) and ozs. and the adding code for the part number:

Code	Preload (N)	(oz.)	Rated Force (N)	(oz.)
<u>10</u>	0.3	1.04	1.0	3.46
<u>18</u>	0.8	2.77	1.8	6.23
<u>25</u>	1.2	4.14	2.5	8.65

Further Technical Data:

Minimum centre spacing:	2.54	mm	.1	inches
Extension height:	6	mm	.236	inches
Overall length:	24.7	mm	.972	inches
Barrel diameter:	1.36	mm	.054	inches
Plunger shaft diameter:	1	mm	.039	inches
Maximum travel:	4	mm	.157	inches
Recommended (rated) travel:	2.7	mm	.106	inches
Temperature range:	-55°C ... +105°C		-67°F ... +221°F	
Typical electrical resistance:	25	mΩ		
Rated electrical current load:	2	amps		
Maximum current load:	3	amps		
Typical life-time in cycles:	2 x 10 ⁶	cycles		

Further spring forces and head styles available on request. Please allow longer delivery for special configurations.

In diameter nearly the same as the series 100 but shorter in overall-length and travel. For combinational use with series 751 (75 MIL centres) and series 14 (50 MIL centres).

Materials:

Plunger:	CuBe, gold plated
Barrel:	Copper Alloy, gold plated
Spring:	Music Wire, gold plated

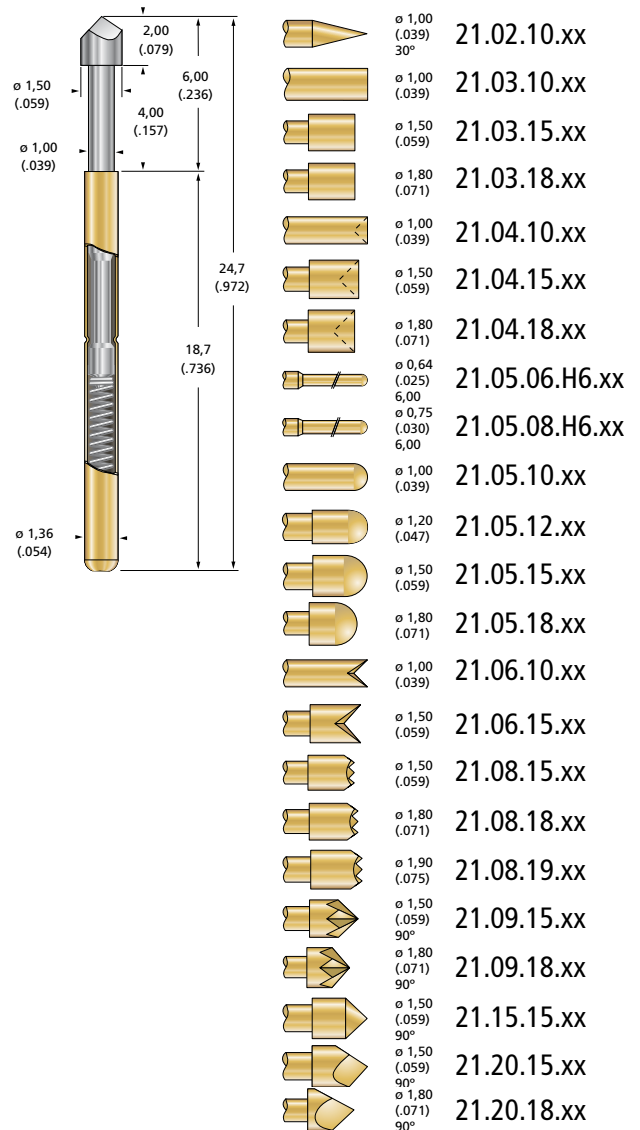

Special models for Tester Interfaces

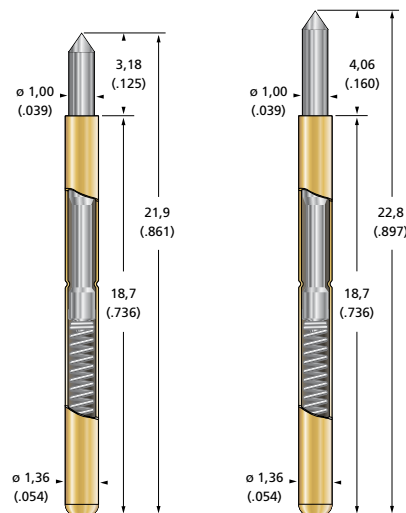

GR1.02.10.11
Spring Force 4.0 oz.

GR2.02.10.10
Spring Force 3.6 oz.

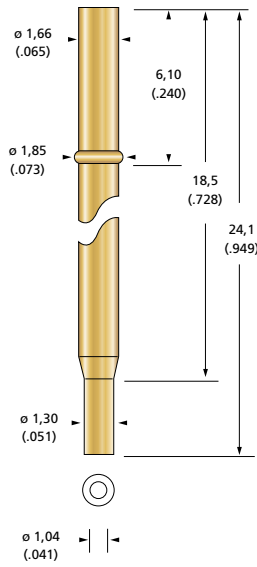

S 21.00-C
Open Crimp End

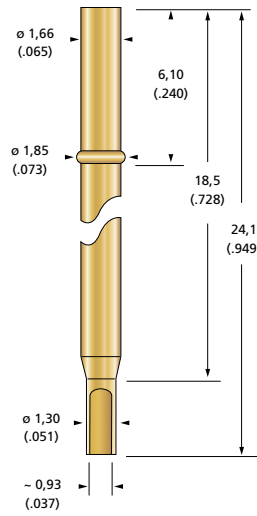

S 21.00-L
Solder Cup

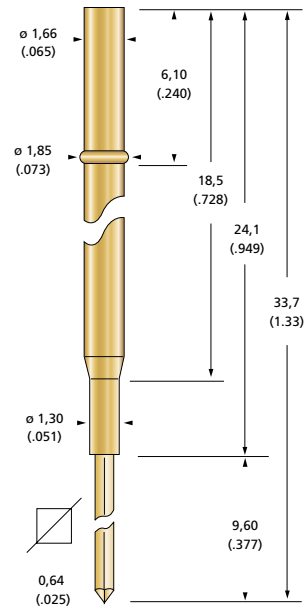

S 21.00-W
Wire-Wrap-Post

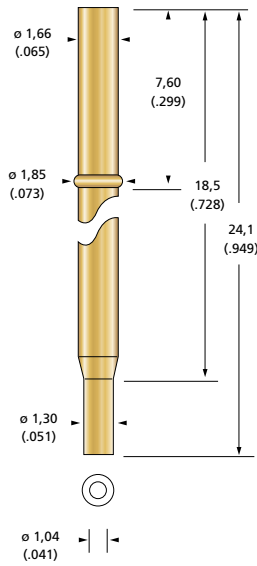

S 21.01-C
Open Crimp End

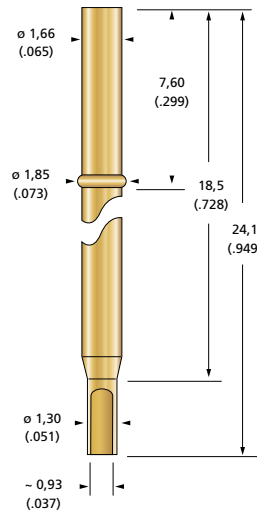

S 21.01-L
Solder Cup

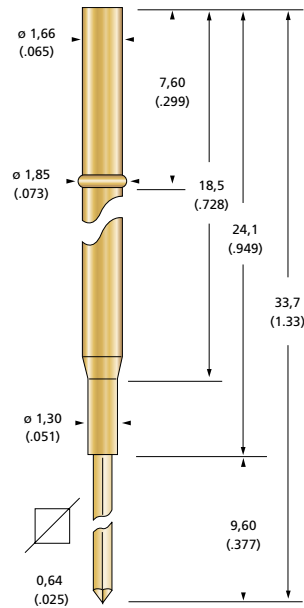

S 21.01-W
Wire-Wrap-Post

For the installation of the receptacles the mounting plate requires precise drilling. In the fixture business there are some typical base materials used for the pin plates which are different in drill bit diameters and machining parameters. The table is showing the recommended drill diameter and the order numbers needed when ordering drill bits from us. For machining parameters please consult factory.

Receptacle with Press-Ring, pressed into Plate Material			
Material	Drill- ϕ		Part No.
CEM1 (also called EP105)	.0689 in.	1.75 mm	500-0175
FR4 (G10, Hgw 2372 or Hgw 2372.1)	.0701 in.	1.78 mm	500-0178
Press-Ring or Stop Ring used as a Collar			
CEM1 (also called EP105)	.0665 in.	1.69 mm	500-0169
FR4 (G10, Hgw 2372 or Hgw 2372.1)	.0669 in.	1.70 mm	500-0170