

The list is showing all head-styles which are available in the series 30.

Silver drawing means: head with steel core.

The number shown right besides every picture is the part number used for ordering. Please replace the field "xx" by the spring force value you'd like to have. The available spring options are listed below.

Example of a completed ordering number:

30.02.07.08

Available spring forces with values in Newton (N) and ozs. and the adding code for the part number:

| Code | Preload (N) | (oz.) | Rated Force (N) | (oz.) |
|------|-------------|-------|-----------------|-------|
| 08 | 0.3 | 1.04 | 0.8 | 2.77 |
| 15 | 0.9 | 3.11 | 1.5 | 5.19 |
| 30 | 1.2 | 4.15 | 3.0 | 10.38 |
| 50 | 2.0 | 6.92 | 5.0 | 17.30 |

Further Technical Data:

| | | | | |
|--------------------------------|---------------------|--------|------------------|--------|
| Minimum centre spacing: | 2.54 | mm | .1 | inches |
| Extension height: | 10 | mm | .394 | inches |
| Overall length: | 32.5 | mm | 1.28 | inches |
| Barrel diameter: | 1.66 | mm | .065 | inches |
| Plunger shaft diameter: | 1.3 | mm | .051 | inches |
| Maximum travel: | 5 | mm | .197 | inches |
| Recommended (rated) travel: | 3.3 | mm | .13 | inches |
| Temperature range: | -55°C ... +105°C | | -67°F ... +221°F | |
| Typical electrical resistance: | 20 | mΩ | | |
| Rated electrical current load: | 3 | amps | | |
| Maximum current load: | 4 | amps | | |
| Typical life-time in cycles: | 1 x 10 ⁶ | cycles | | |

Further spring forces and head styles available on request. Please allow longer delivery for special configurations.

For use in 100 MIL centres many European customers use metric probes besides the imperial sized probes which became a common standard today. The differences between these two "worlds" are the design of the barrel housing and the drill sizes for the mounting holes.

Different from the inch-type probes with press-ring design, metric receptacles always have a fixed limit stop. To achieve different contact levels, you have the choice of several probe barrel types within each "family". The probe barrel has a limit stop-ring, which can be at different positions. Receptacles are always installed at the same full-stop level, and all spring contact probes of the same family fit into these receptacles. For intermediate levels spacers of 1,2 or 3 mm length are available. The metric probes for 100 MIL centres require a mounting hole of exactly 2 mm, which can be drilled with a standard drill bit.

Last but not least the metric sizes are appr. 22% larger in diameter than equivalent inch-type probes. Due to the better stability, the larger conductor diameter and bigger space for the spring inside the barrel, the metric probes are often used in applications with harsh conditions.

Materials:

| | |
|----------|--|
| Plunger: | CuBe or Steel, hard gold plated 400 HV |
| Barrel: | Nickelsilver, gold plated |
| Spring: | Music Wire, silver plated |

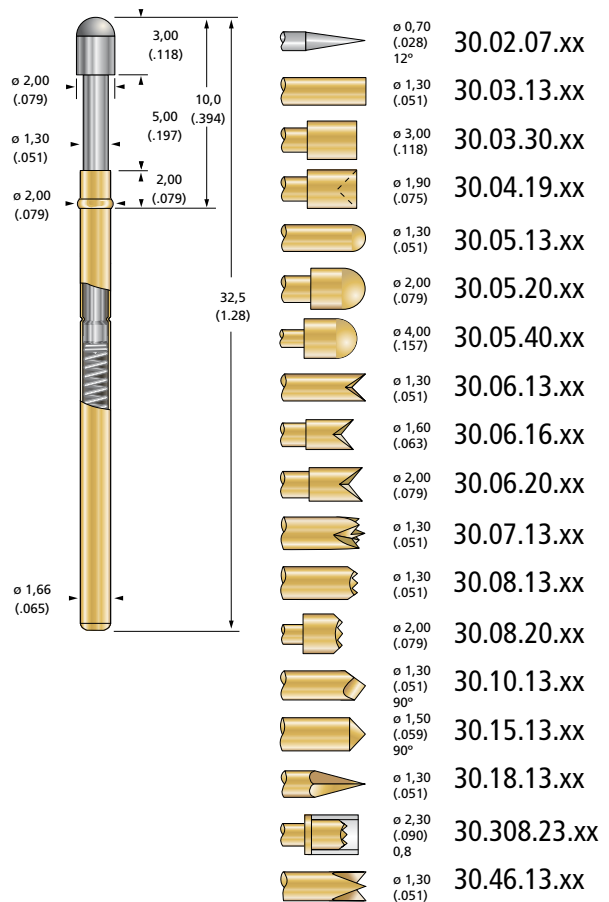

D 30.01
 Tube Spacer 1 mm

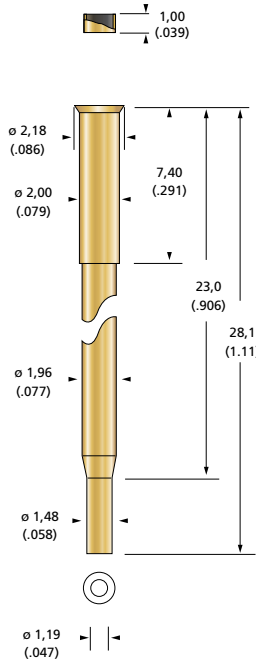

S 30.00-C
 Open Crim End

D 30.02
 Tube Spacer 2 mm

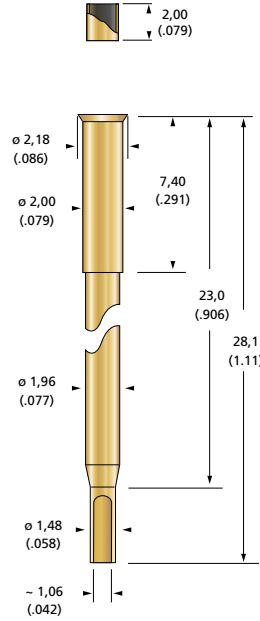

S 30.00-L
 Solder Cup

D 30.03
 Tube Spacer 3 mm

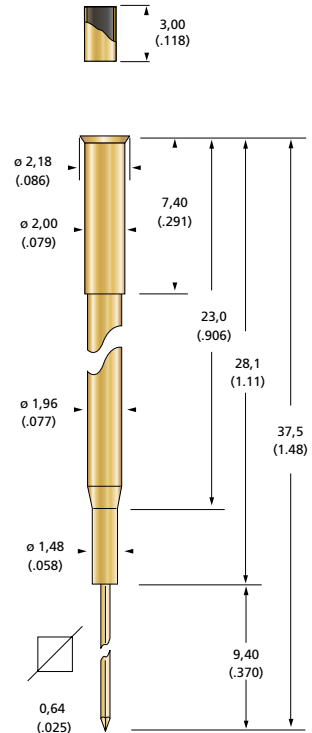

S 30.00-W
 Wire-Wrap-Post

Further terminations available on request (e.g. with pre-attached wire).

Using different combinations of probe collar height and tube spacers, a large number of variations for the dimension "E" is achievable.

On the following 6 pages you will find further probe types, which all use receptacles and tube spacers of series 30.

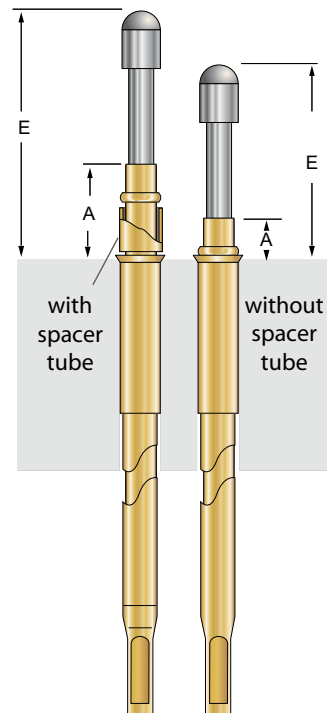

For the installation of the receptacles the mounting plate requires precise drilling. In the fixture business there are some typical base materials used for the pin plates which are different in drill bit diameters and machining parameters. The table below is showing the recommended drill diameter and the order numbers needed when ordering drill bits from us. For machining parameters please consult factory.

| Press-Ring or Stop Ring used as a Collar | | | |
|--|---------------|---------|----------|
| Material | Drill- ϕ | | Part No. |
| CEM1 (also called EP105) | .0787 in. | 2.00 mm | 500-0200 |
| FR4 (G10, Hgw 2372 or Hgw 2372.1) | .0787 in. | 2.00 mm | 500-0200 |